

# STRUCTURAL REPORT

For

## Lantana Oceanfront Condominiums Building 4 - 1851 Florida A1A Indian Harbour Beach, Florida 32937

Prepared by:  
Jose Antonio Tolosa, E.I.

Approved by:  
Rodolfo Villamizar, P.E.



CIVIL ■ STRUCTURAL ■ SURVEYING ■ ENVIRONMENTAL

1835 20th Street ■ Vero Beach, FL 32960  
**772.569.0035 ■ Fax: 772.778.3617**  
**www.mbveng.com**

CA#3728

Engineer's Project # 21-0530  
January 6, 2022

---

1835 20th Street  
Vero Beach, FL 32960  
772.569.0035  
Fax: 772.778.3617

1250 W. Eau Gallie Blvd., Unit H  
Melbourne, FL 32935  
321.253.1510  
Fax: 321.253.0911

806 Delaware Avenue  
Ft. Pierce, FL 34950  
772.468.9055  
Fax: 772.778.3617



Lantana Oceanfront Condominiums  
Project # 21-0530  
January 6, 2022

## Table of Contents

1. Executive Summary
2. Description of Structure
3. Scope of Investigation and Limitations
4. Findings and Repair Recommendations
5. Conclusions

### APPENDICES

Appendix A Unit balcony findings drawings



Lantana Oceanfront Condominiums

Project # 21-0530

January 6, 2022

## 1. Executive Summary

MBV Engineering, Inc. is pleased to submit this report following our directed, limited inspection and evaluation of the balconies of units 4202, 4203, 4204, 4205, 4302, 4303, 4304, 4305, 4402, 4403, 4404 and 4405, in Building No. 4, at Lantana Oceanfront Condominiums. This study was specifically requested to determine significances and extent of defects noted in the slabs, columns, and exterior walls at each unit balcony.

Representatives of MBV Engineering, Inc. inspected the above referenced unit balconies on Tuesday December 14, 2021 and Wednesday December 15, 2021.

## 2. Description of Structure

The Lantana Oceanfront Condominiums are located on Indian Harbor Beach, by Cocoa Beach, on SR A1A in Brevard County. The property consists of Four (4) 4-story residential building structures, detached parking/garage building structures, a recreation building structure and an in-ground pool. The front of the residential building structures faces the west. The buildings are rectangular shaped. The buildings were originally constructed in the year 2,000.

We inspected twelve (12), elevated, east exposure, interior location, unit balconies in Building No. 4. The structural system for the elevated slabs is a two-way flat concrete post-tension reinforced 6-inches thick floor slab and roof slab supported primarily on reinforced concrete columns; the exterior walls are infill masonry with stucco finishes. The building structure is supported on deep foundations.

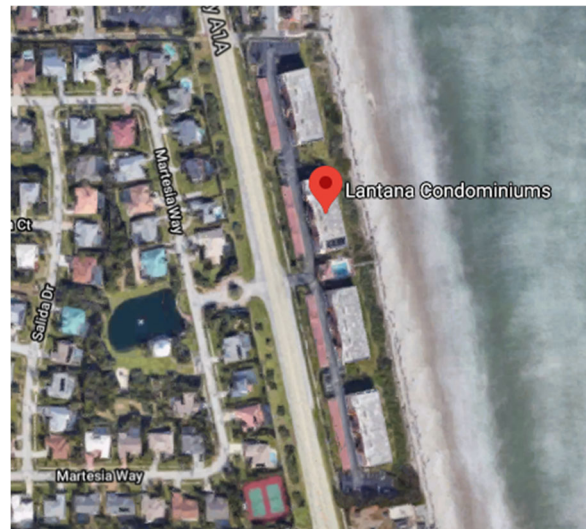

## 3. Scope of Investigation and Limitations

The purpose of our inspection was to review the condition of the balcony slabs, columns and walls as they now stand, and to determine the elements which require structural (and/or cosmetic) repair.

Our visual and preliminary inspections are not expected to reveal elaborate defects, which are not evident by deterioration exposed to view or evident to the trained eye as the elements now stand. It must be understood that the Engineer can only provide certification of the conditions of the elements within the limits of the inspection performed; whether the materials, sizes, dimensions, connections, or its construction are structurally adequate or have weaknesses is beyond the extent of the inspection performed and is out of the scope of this assessment.

Our assessment included an audio visual (non-destructive) inspection of the accessible exterior balcony concrete slab structure. The existing floor surfaces are finished with a cementitious overlay / topping covering the concrete floor structure. Similarly, the existing ceiling surfaces have a plaster / stucco finish that covers the underside of the concrete slabs.



Lantana Oceanfront Condominiums

Project # 21-0530

January 6, 2022

We marked, with a color chalk, the floor surfaces that currently show signs of distress; some of these areas are confirmed active concrete slab spalling and some are suspect and will require further verification after the existing floor finishes are removed.

For this investigation, we were provided with a copy of the structural drawings, as designed by Gerding Engineering, revision 3, dated 02-18-1998. Our evaluation and recommendations are being done with emphasis on the slab framing layout, and the location and conditions of the post-tensioning system, as shown in those structural plans, that are directly affected or in the vicinity of the noted slab problem areas.

- We took multiple photographs to document the conditions and to record signs of distressed elements and defects at the date and time of the inspection.
- We performed acoustic soundings by means of a hammer (or the use of a rotary percussion sounding device, per ASTM D4580-03) to help identify/confirm material delamination and or damage.

#### **4. Findings and Repair Recommendations**

These balcony slabs are undergoing different stages and rate of deterioration within a particular slab and from one slab to another, ranging from incipient or minor concrete deterioration as evidenced by surface rust spots and nearly inaudible hollow sounding to severe deterioration due to heavy reinforcement corrosion, with obvious concrete spalling, cracking and exposed reinforcement.

The intent of the sounding procedure was to hear a dull or hollow sound indicating any delamination. Hollow sounding is an indication of concrete spalling, delamination or detached layers of concrete; it means the concrete is undergoing deterioration due to corrosion of the reinforcement.

A concrete restoration plan that can effectively repair the problems found and address the root causes will not only help reduce the rate of concrete deterioration but will delay their future recurrence.

Due to the inherent catastrophic failure potential from ruptured tendons from abuse or neglect, particular care, attention and prompt actions should be implemented with post-tensioned reinforced slab systems.

The following are the noted damages (and our recommended repairs) per each unit.:

- **Unit 4202**
  - Identified several evident hollow sounding floor overlay / topping area locations. The existing floor finishes directly over the identified hollow sounding floor surfaces should be removed to further verify and rule out the possibility of being actual concrete slab spalling.
  - Found a couple small area locations of hollow sounding overhead ceiling plaster near the top shutter track. Remove and install new stucco / plaster.
  - For more information see attached finding drawings.



- **Unit 4203:**
  - Identified several evident hollow sounding floor overlay / topping area locations. The existing floor finishes directly over the identified hollow sounding floor surfaces should be removed to further verify and rule out the possibility of being actual concrete slab spalling.
  - For more information see attached finding drawings.
  
- **Unit 4204:**
  - Identified a few evident hollow sounding floor overlay / topping area locations. The existing floor finishes directly over the identified hollow sounding floor surfaces should be removed to further verify and rule out the possibility of being actual concrete slab spalling.
  - For more information see attached finding drawings.
  
- **Unit 4205:**
  - Identified several evident hollow sounding floor overlay / topping area locations. The existing floor finishes directly over the identified hollow sounding floor surfaces should be removed to further verify and rule out the possibility of being actual concrete slab spalling.
  - For more information see attached finding drawings.
  
- **Unit 4302:**
  - Identified a slab concrete spall in the north end of the balcony under the shutter bottom track.
  - Identified several evident hollow sounding floor overlay / topping area locations. The existing floor finishes directly over the identified hollow sounding floor surfaces should be removed to further verify and rule out the possibility of being actual concrete slab spalling.
  - Observed water ponding locations. A pitch correction to these locations is recommended to ensure the proper draining away of water.
  - For more information see attached finding drawings.
  
- **Unit 4303:**
  - Possible concrete spall located by the south interior corner in front of the living room. This area is directly aligned with the band group of tendons (N-S orientation) along column grid line A. Both banded tendons and uniform tendons (E-W orientation) may be impacted (and may require de-tensioning / re-tensioning to allow the slab concrete repairs) if located directly over the possible slab spalling/repair areas.
  - Identified several evident hollow sounding floor overlay / topping area locations. The existing floor finishes directly over the identified hollow sounding floor surfaces should be removed to further verify and rule out the possibility of being actual concrete slab spalling.
  - For more information see attached finding drawings.



- **Unit 4304:**
  - Possible concrete spall located by the north interior corner in front of the living room. This area is directly aligned with the band group of tendons (N-S orientation) along column grid line A. Both banded tendons and uniform tendons (E-W orientation) may be impacted (and may require de-tensioning / re-tensioning to allow the slab concrete repairs) if located directly over the possible slab spalling/repair areas.
  - Identified several evident hollow sounding floor overlay / topping area locations. The existing floor finishes directly over the identified hollow sounding floor surfaces should be removed to further verify and rule out the possibility of being actual concrete slab spalling.
  - For more information see attached finding drawings.
  
- **Unit 4305:**
  - Identified several evident hollow sounding floor overlay / topping area locations. The existing floor finishes directly over the identified hollow sounding floor surfaces should be removed to further verify and rule out the possibility of being actual concrete slab spalling.
  - For more information see attached finding drawings.
  
- **Unit 4402:**
  - Identified several evident hollow sounding floor overlay / topping area locations. The existing floor finishes directly over the identified hollow sounding floor surfaces should be removed to further verify and rule out the possibility of being actual concrete slab spalling.
  - Identified a couple locations of hollow sounding overhead ceiling plaster near the drip edge. Remove and install new stucco / plaster.
  - For more information see attached finding drawings.
  
- **Unit 4403:**
  - Identified several evident hollow sounding floor overlay / topping area locations. The existing floor finishes directly over the identified hollow sounding floor surfaces should be removed to further verify and rule out the possibility of being actual concrete slab spalling.
  - Identified a location of hollow sounding overhead ceiling plaster near the drip edge. Remove and install new stucco / plaster.
  - For more information see attached finding drawings.
  
- **Unit 4404:**
  - Identified several evident hollow sounding floor overlay / topping area locations. The existing floor finishes directly over the identified hollow sounding floor surfaces should be removed to further verify and rule out the possibility of being actual concrete slab spalling.
  - Identified a couple locations of hollow sounding overhead ceiling plaster near the drip edge. Remove and install new stucco / plaster.
  - For more information see attached finding drawings.



Lantana Oceanfront Condominiums

Project # 21-0530

January 6, 2022

- **Unit 4405:**
  - The existing accordion shutters were closed at the time of the inspection. The edge of the slab was not accessible.
  - The interior floor and ceiling surfaces were checked and appear to be OK. No hollow sounding / delaminated surfaces observed.
  - For more information see attached finding drawings.

## 5. **Conclusions**

A concrete restoration process should be implemented to properly repair the observed damages following the guidelines of the ICRI (International Concrete Repair Institute, Inc.) and the PTI (Post-Tensioning Institute).

ICRI methodology requires unsound concrete to be removed; affected reinforcement exposed until at least 4 to 6 inches of clean steel is encountered. The exposed steel will then be abrasively cleaned in order to remove the chlorides attached to it. Corroded steel tends to lose cross-section area and will need supplements if a threshold is reached.

Concrete is then redone with corrosion inhibitors and low water cement ratios; the reinforcement is treated / coated with corrosion inhibitors after being thoroughly cleaned and an adequate waterproofing system is installed on all horizontal and vertical concrete slab surfaces. Migrating corrosion inhibitors should be applied to the concrete surfaces that are not receiving a waterproofing system. As a part of the waterproofing system, we also recommend the application of an adequate slab edge treatment at the juncture with the walls in order to properly seal and waterproof the balcony edge / perimeter. Also, the slab slope (pitch) will need to be reviewed to ensure proper water drainage away from the unit.

Any cracks on the concrete members should be epoxy injected in order to repair the structural capacity of the affected elements.

We do not recommend the use of elastomeric paints on the exterior wall or ceiling surfaces.

The significant damages observed on the floor overlay / topping slabs on some of the units seem premature as the building is 20 years old but are consistent with the location of the buildings due to their proximity to the ocean and the fact that these slabs are not properly being waterproofed.

The Board should consider initiating a repair project to address as many of the repairs as can be afforded. These repairs should address the immediate damage and are aimed at taking preventative measures to slow the rates of corrosion; including waterproofing before covering the floors with acrylic paint.

We feel by using the proposed methods of repair, it will be able to efficiently mitigate the damages to the structure and adequately ensure that the strength of the members is not exceeded by the design loads.



Lantana Oceanfront Condominiums

Project # 21-0530

January 6, 2022

Should you have any questions regarding the above subject, please do not hesitate to contact our office.

Very truly yours,

Rodolfo Yillamizar, P.E.

FL PE# 61000

RV/jt

# **Appendix A**

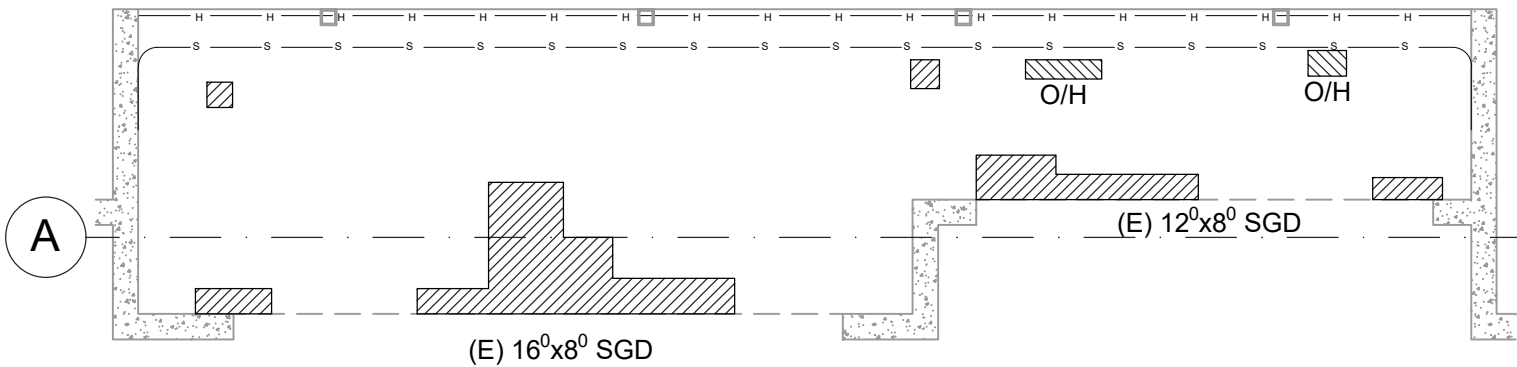

**UNIT 4202**

**LEGEND:**

SLAB PARTIAL DEPTH REPAIR (SF)



HANDRAIL



ACCORDION SHUTTERS



**NOTE: REMOVE TOPPING ON HOLLOW SOUNDING AREAS TO CONFIRM IF IT IS THE TOPPING THAT IS HOLLOW OR THE CONCRETE IS SPALLING.**

RODOLFO VILLAMIZAR  
FL. P.E.#61000

DATE:

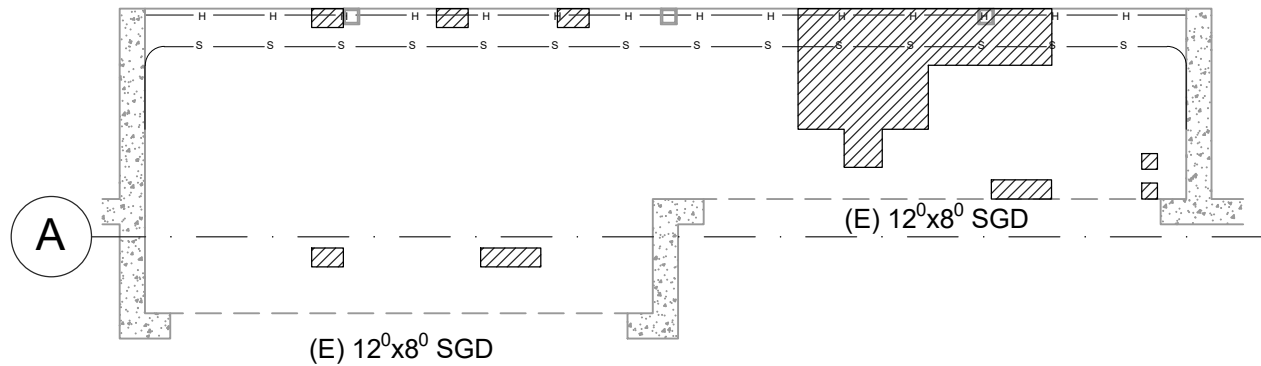

**UNIT 4203**

**LEGEND:**

SLAB PARTIAL DEPTH REPAIR (SF)

HANDRAIL — H — H —

ACCORDION SHUTTERS — S — S —

- REMOVABLE COMPOSITE TILE.
- BRAND NEW SHUTTERS.

**NOTE: REMOVE TOPPING ON HOLLOW SOUNDING AREAS TO CONFIRM IF IT IS THE TOPPING THAT IS HOLLOW OR THE CONCRETE IS SPALLING.**

RODOLFO VILLAMIZAR  
FL. P.E.#61000

---

DATE:

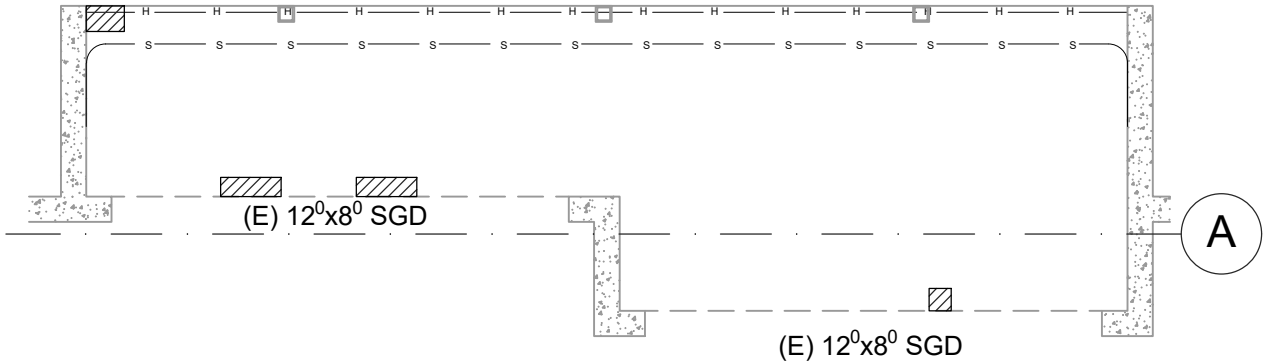

**UNIT 4204**

**LEGEND:**

SLAB PARTIAL DEPTH REPAIR (SF) 

HANDRAIL 

ACCORDION SHUTTERS 

**NOTE: REMOVE TOPPING ON HOLLOW SOUNDING AREAS TO CONFIRM IF IT IS THE TOPPING THAT IS HOLLOW OR THE CONCRETE IS SPALLING.**

RODOLFO VILLAMIZAR  
FL. P.E.#61000

DATE:

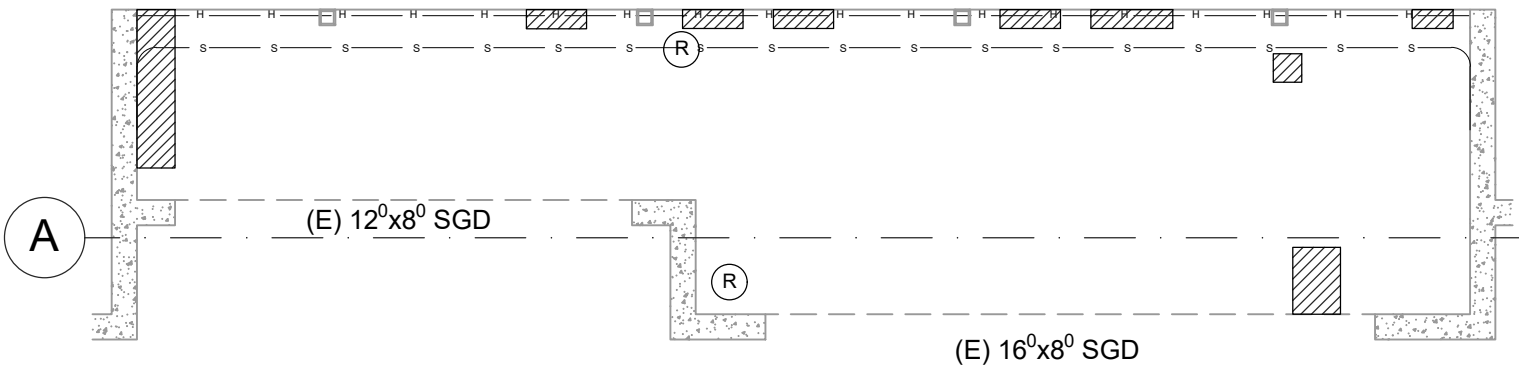

**UNIT 4205**

**LEGEND:**

SLAB PARTIAL DEPTH REPAIR (SF)



HANDRAIL



ACCORDION SHUTTERS

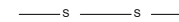

RUST SPOTS (EA)



NOTE: REMOVE TOPPING ON HOLLOW SOUNDING AREAS TO CONFIRM IF IT IS THE TOPPING THAT IS HOLLOW OR THE CONCRETE IS SPALLING.

RODOLFO VILLAMIZAR  
FL. P.E.#61000

DATE:

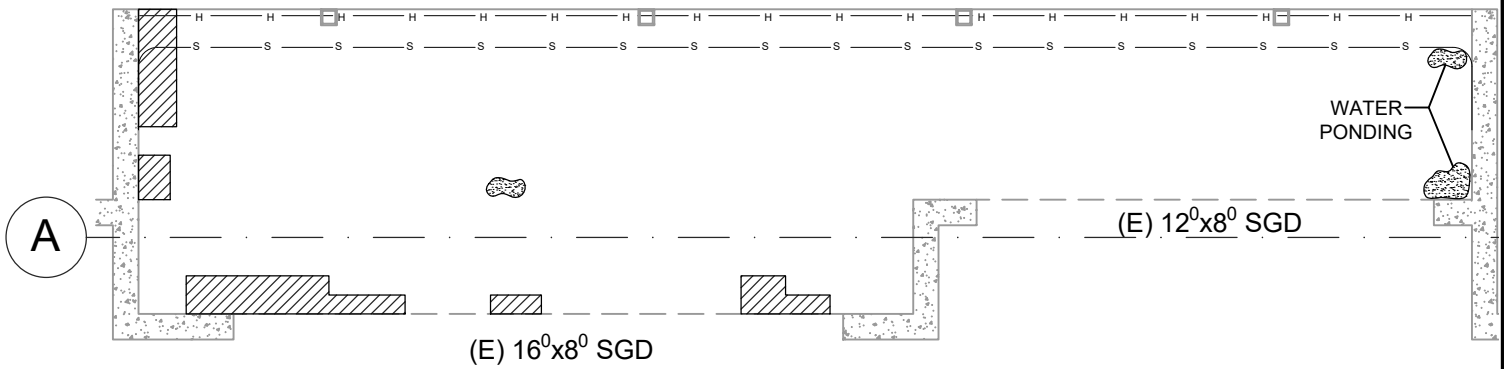

**UNIT 4302**

**LEGEND:**

SLAB PARTIAL DEPTH REPAIR (SF)



HANDRAIL



ACCORDION SHUTTERS

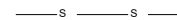

**NOTE: REMOVE TOPPING ON HOLLOW SOUNDING AREAS TO CONFIRM IF IT IS THE TOPPING THAT IS HOLLOW OR THE CONCRETE IS SPALLING.**

RODOLFO VILLAMIZAR  
FL. P.E.#61000

DATE:

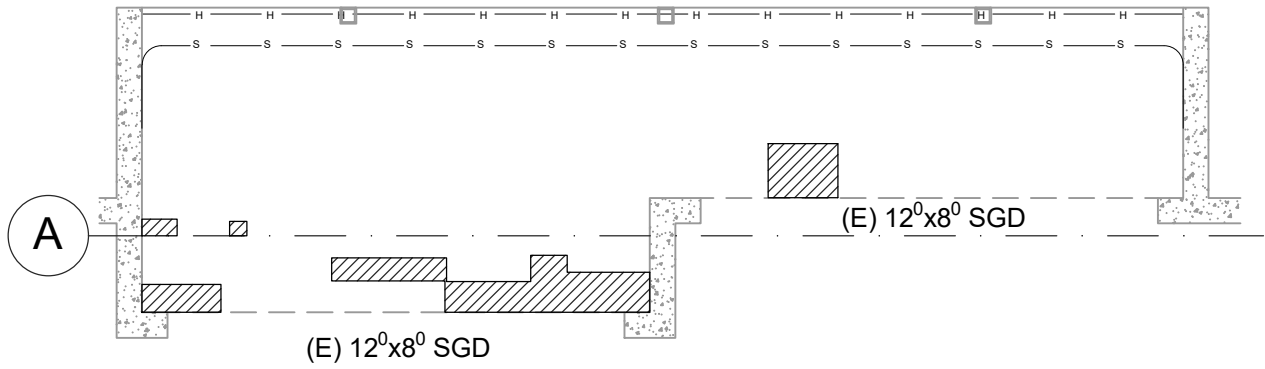

**UNIT 4303**

**LEGEND:**

SLAB PARTIAL DEPTH REPAIR (SF) 

HANDRAIL 

ACCORDION SHUTTERS 

- PAINT DECK PEELING/BLISTER.
- ABANDONED WALL SCREWS OH.

**NOTE: REMOVE TOPPING ON HOLLOW SOUNDING AREAS TO CONFIRM IF IT IS THE TOPPING THAT IS HOLLOW OR THE CONCRETE IS SPALLING.**

RODOLFO VILLAMIZAR  
FL. P.E.#61000

DATE:

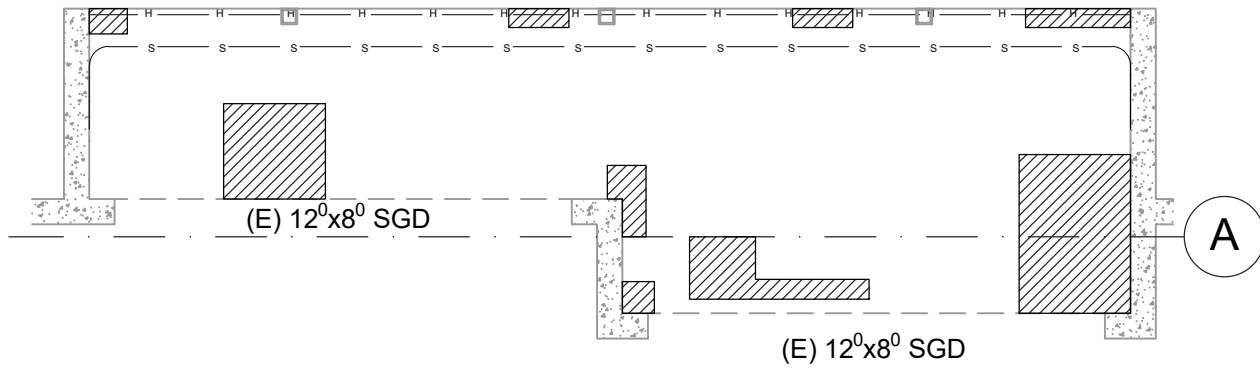

**UNIT 4304**

**LEGEND:**

SLAB PARTIAL DEPTH REPAIR (SF)

HANDRAIL — H — H —

ACCORDION SHUTTERS — S — S —

**NOTE: REMOVE TOPPING ON HOLLOW SOUNDING AREAS TO CONFIRM IF IT IS THE TOPPING THAT IS HOLLOW OR THE CONCRETE IS SPALLING.**

RODOLFO VILLAMIZAR  
FL. P.E.#61000

---

DATE:

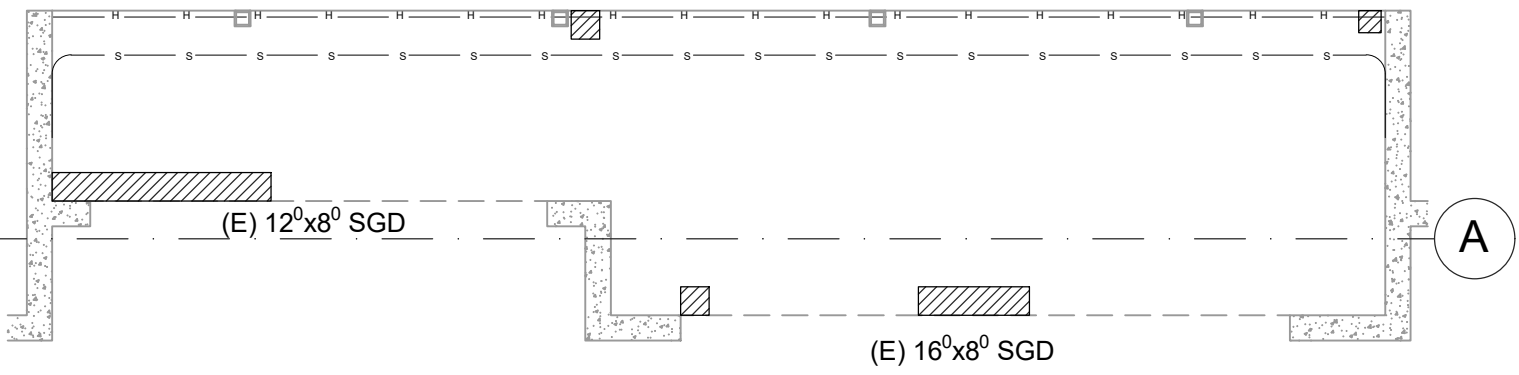

**UNIT 4305**

**LEGEND:**

- SLAB PARTIAL DEPTH REPAIR (SF)
- HANDRAIL — H — H —
- ACCORDION SHUTTERS — S — S —

- SHUTTER PINS ARE DAMAGED.
- SHUTTERS TOP TRACK ABANDONED SCREWS.

**NOTE: REMOVE TOPPING ON HOLLOW SOUNDING AREAS TO CONFIRM IF IT IS THE TOPPING THAT IS HOLLOW OR THE CONCRETE IS SPALLING.**

RODOLFO VILLAMIZAR FL. P.E.#61000
DATE:

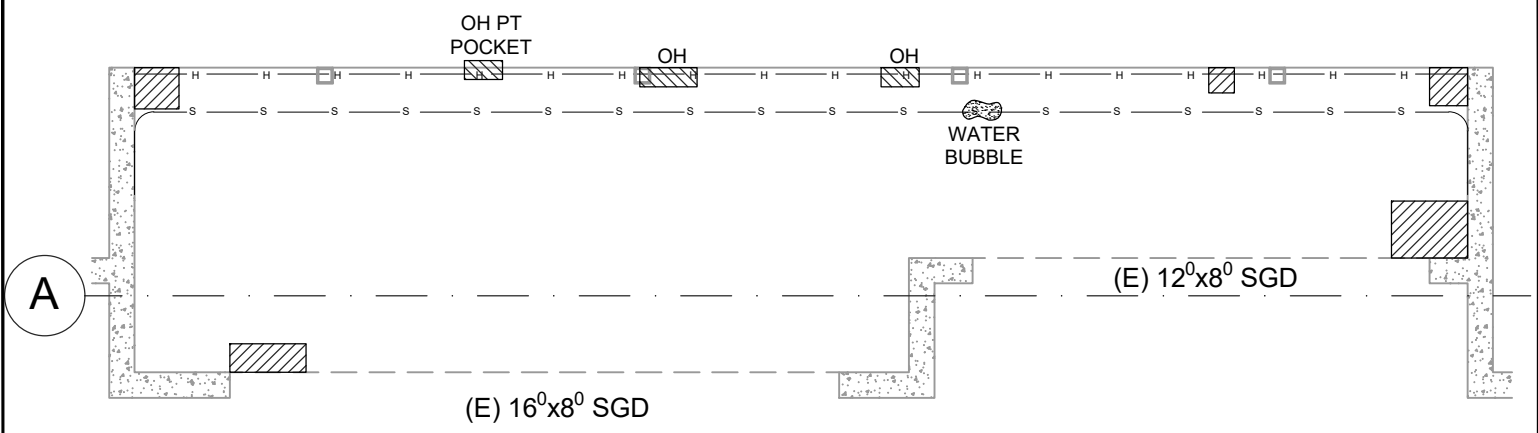

**UNIT 4402**

**LEGEND:**

SLAB PARTIAL DEPTH REPAIR (SF)



HANDRAIL

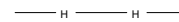

ACCORDION SHUTTERS



- SOME MISSING SCREWS ON SHUTTERS (TOP TRACK).
- BOTTOM TRACKS RAISED W/ SHIMS.
- PAINT BLISTER OH ROOF EDGE

**NOTE: REMOVE TOPPING ON HOLLOW SOUNDING AREAS TO CONFIRM IF IT IS THE TOPPING THAT IS HOLLOW OR THE CONCRETE IS SPALLING.**

RODOLFO VILLAMIZAR  
FL. P.E.#61000

---

DATE:

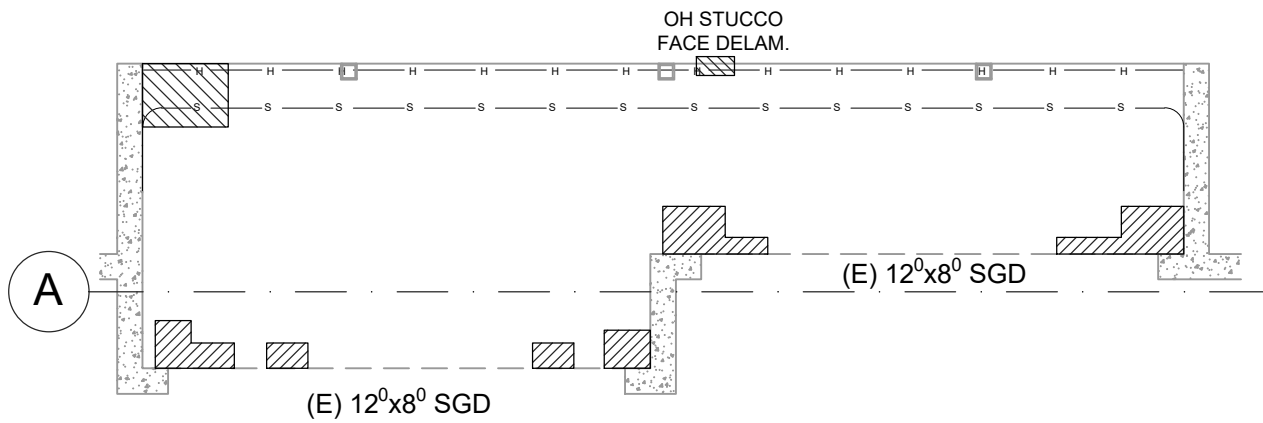

**UNIT 4403**

**LEGEND:**

SLAB PARTIAL DEPTH REPAIR (SF)

HANDRAIL — H — H —

ACCORDION SHUTTERS — S — S —

- SGD TOP TRACK CORRODED FASTENERS.
- MISSING SCREWS ON TOP TRACK.

**NOTE: REMOVE TOPPING ON HOLLOW SOUNDING AREAS TO CONFIRM IF IT IS THE TOPPING THAT IS HOLLOW OR THE CONCRETE IS SPALLING.**

RODOLFO VILLAMIZAR FL. P.E.#61000
DATE:

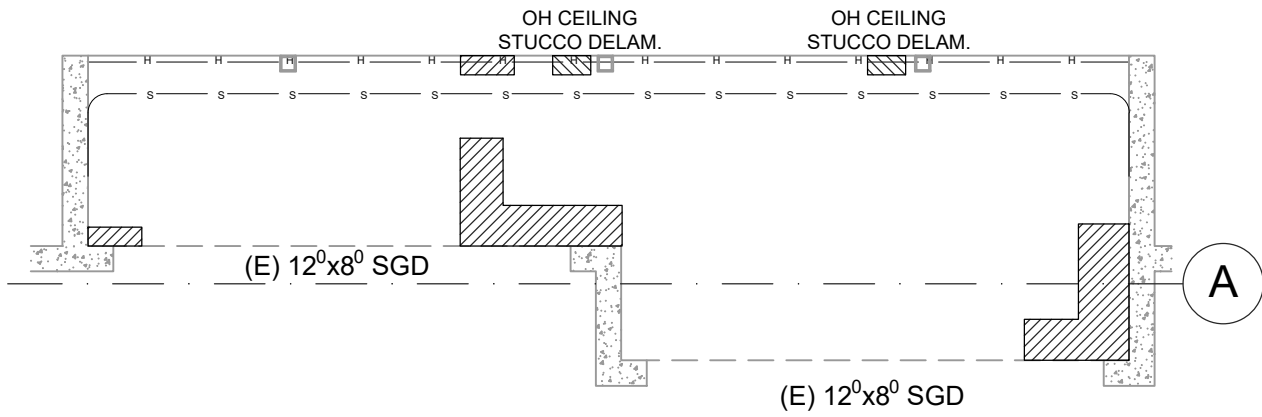

**UNIT 4404**

**LEGEND:**

SLAB PARTIAL DEPTH REPAIR (SF) 

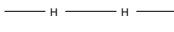
HANDRAIL 

ACCORDION SHUTTERS 

**NOTE: REMOVE TOPPING ON HOLLOW SOUNDING AREAS TO CONFIRM IF IT IS THE TOPPING THAT IS HOLLOW OR THE CONCRETE IS SPALLING.**

RODOLFO VILLAMIZAR  
FL. P.E.#61000

DATE:

LANTANA  
CONDOMINIUM  
BALCONY INSPECTION  
1811 A1A  
INDIAN HARBOUR BEACH, FL

FINDINGS/REPAIRS

**MBV**  
**ENGINEERING, INC.**  
MOIA BOWLES VILLAMIZAR & ASSOCIATES  
CONSULTING ENGINEERING CA #3728

1835 - 20TH STREET  
VERO BEACH, FL 32960  
PH. (772) 569-0035  
FX. (772) 778-3617

MELBOURNE, FL - PH (321) 253-1510  
FT. PIERCE, FL - PH (772) 468-9055

JOB NO.	21-0530
DESIGNED	JT
DRAWN	AER
CHECKED	RV
DATE	DEC 2021
SHEET	11 OF XX

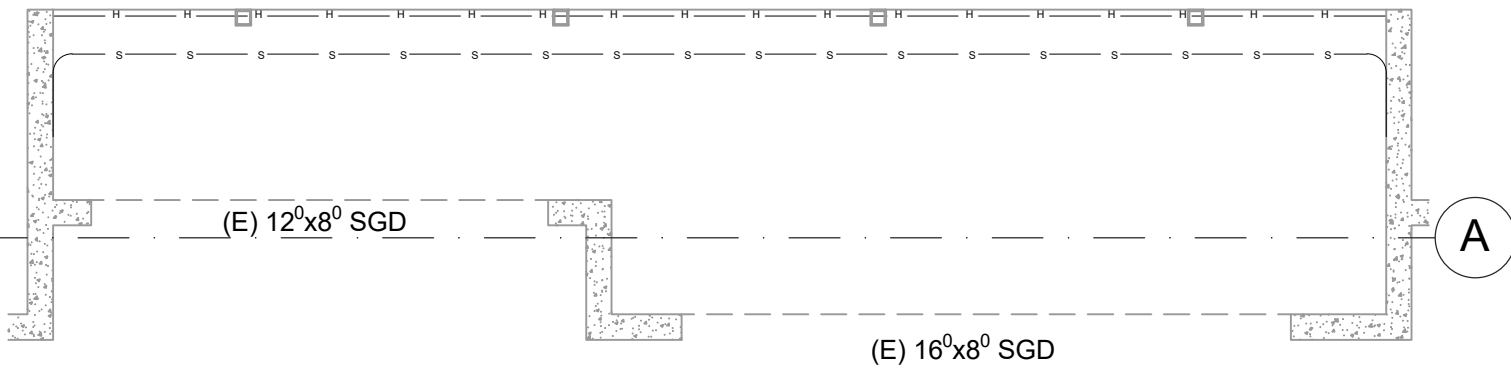

**UNIT 4405**

LEGEND:

SLAB PARTIAL DEPTH REPAIR (SF) 

HANDRAIL 

ACCORDION SHUTTERS 

- PERIMETER SHUTTERS ARE CLOSED.
- PERIMETER SGD CAULKING MUST BE CHANGED.

NOTE: REMOVE TOPPING ON HOLLOW SOUNDING AREAS TO CONFIRM IF IT IS THE TOPPING THAT IS HOLLOW OR THE CONCRETE IS SPALLING.

RODOLFO VILLAMIZAR  
FL. P.E.#61000

DATE:

# CLEANING AND REPAIR OF REINFORCING STEEL

## CLEANING OF REINFORCING STEEL

ALL HEAVY CORROSION AND SCALE SHOULD BE REMOVED FROM THE BAR AS NECESSARY TO PROMOTE MAXIMUM BOND OF REPLACEMENT MATERIAL. OIL FREE ABRASIVE BLAST IS THE PREFERRED METHOD. A TIGHTLY BONDED LIGHT RUST BUILD-UP ON THE SURFACE IS USUALLY NOT DETRIMENTAL TO BOND, UNLESS A PROTECTIVE COATING IS BEING APPLIED TO THE BAR SURFACE, IN WHICH CASE THE COATING MANUFACTURER'S RECOMMENDATIONS FOR SURFACE PREPARATION SHOULD BE FOLLOWED.

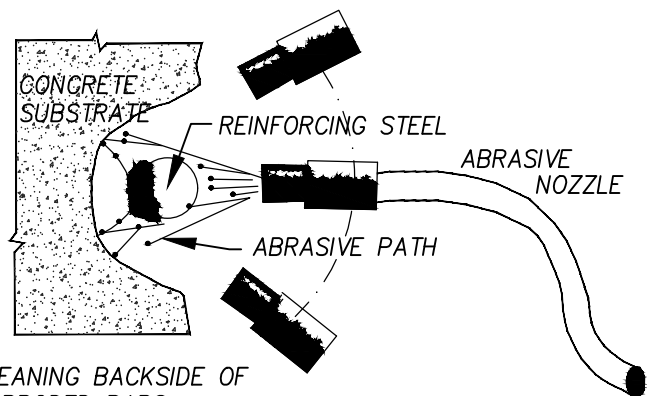

CLEANING BACKSIDE OF CORRODED BARS

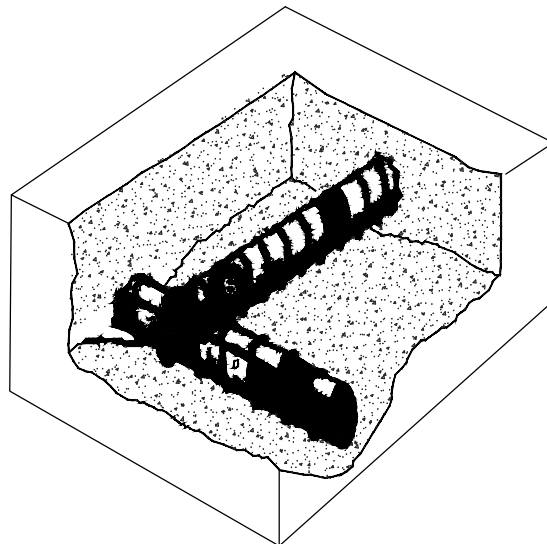

## REPAIR OF REINFORCING STEEL DUE TO LOSS OF SECTION

IF REINFORCING STEEL HAS LOST SIGNIFICANT CROSS SECTION, A STRUCTURAL ENGINEER SHOULD BE CONSULTED. IF REPAIRS ARE REQUIRED TO THE REINFORCING STEEL, ONE OF THE FOLLOWING REPAIR METHODS SHOULD BE USED:

- \* COMPLETE BAR REPLACEMENT, OR
- \* ADDITION OF SUPPLEMENTAL BAR OVER AFFECTED SECTION.

NEW BARS MAY BE MECHANICALLY SPLICED TO OLD BARS OR PLACED PARALLEL TO AND APPROXIMATELY  $\frac{3}{4}$  IN. (19 MM) FROM EXISTING BARS. LAP LENGTHS SHALL BE DETERMINED IN ACCORDANCE WITH ACI 318; ALSO REFER TO CRSI AND AASHTO MANUAL.

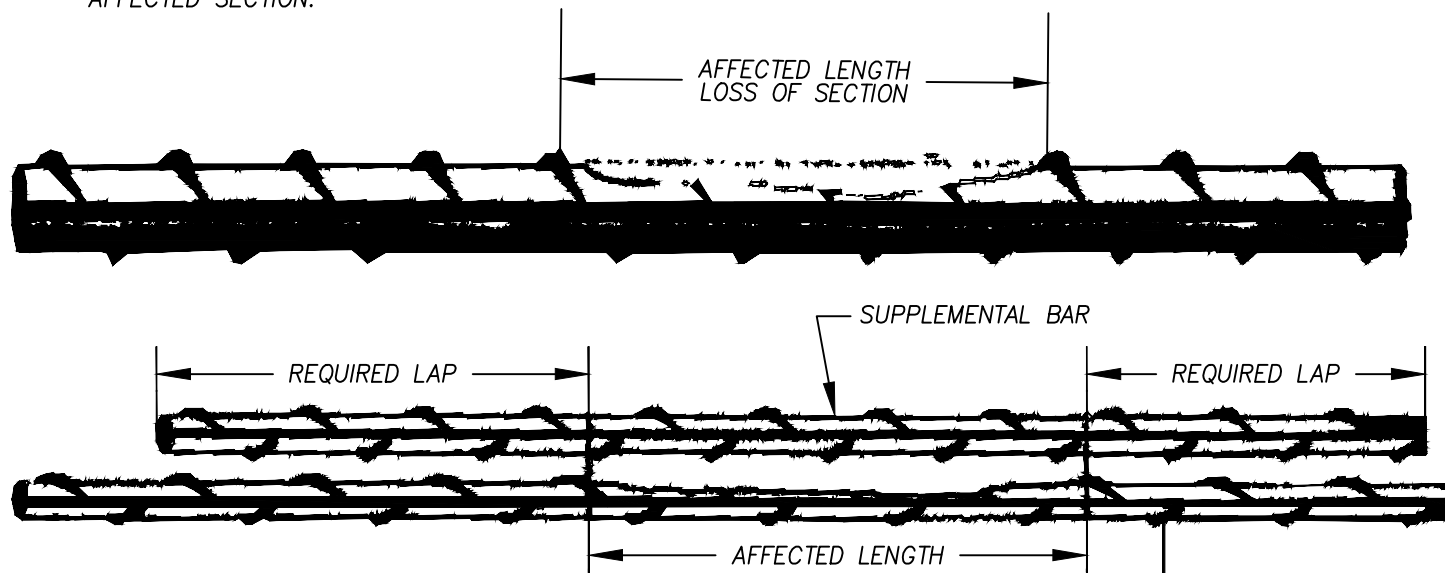

RODOLFO VILLAMIZAR  
FL. P.E.#61000

DATE:

# CONSTRUCTION RESTORATION REMOVAL GEOMETRY

SECTION

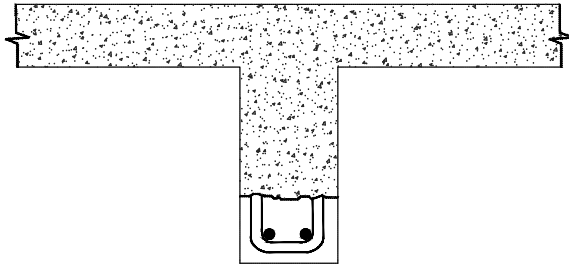

ELEVATION

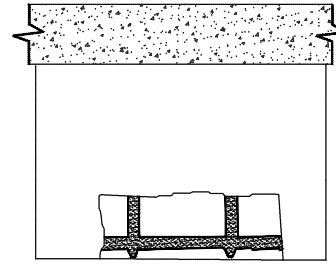

BEAM OR RIB

ELEVATION

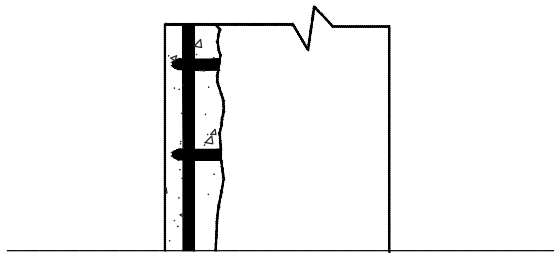

SECTION

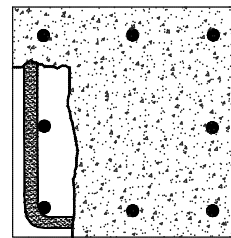

COLUMN CORNER

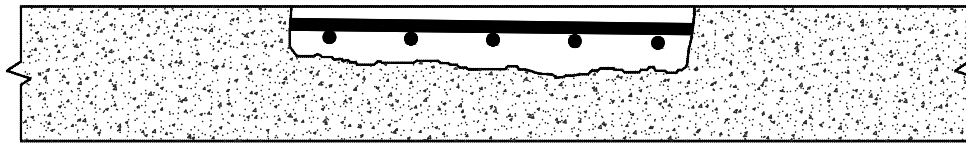

SLAB OR WALL  
PARTIAL DEPTH

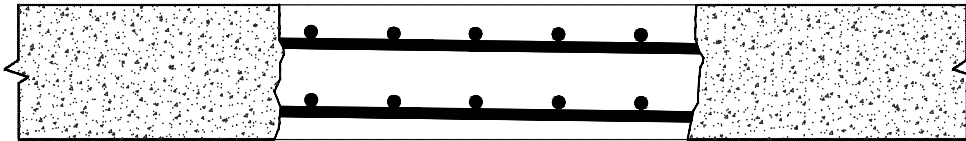

SLAB OR WALL  
FULL DEPTH

CAUTION! BEFORE STARTING REMOVALS, REVIEW EFFECT OF REMOVABLE ON STRUCTURAL INTEGRITY. PROVIDE SHORING OF MEMBER AS NECESSARY. PARTICULAR CARE SHALL BE EXERCISED AT SLAB/BEAM CONNECTIONS TO COLUMNS.

RODOLFO VILLAMIZAR  
FL. P.E.#61000

DATE:

# EDGE AND SURFACE CONDITIONING OF CONCRETE

## EDGE AND SURFACE CONDITIONING OF CONCRETE

1. THESE DETAILS ARE APPLICABLE TO HORIZONTAL, VERTICAL, AND OVERHEAD LOCATIONS. THEY ARE ALSO APPLICABLE TO REMOVAL BY HYDRO-DEMOLITION, HYDROMILLING, AND ELECTRIC, PNEUMATIC OR HYDRAULIC IMPACT BREAKERS.
2. REMOVE DELAMINATED CONCRETE, UNDERCUT REINFORCING STEEL, REMOVE ADDITIONAL CONCRETE AS REQUIRED TO PROVIDE MINIMUM REQUIRED THICKNESS OF REPAIR MATERIAL.
3. CHIP OUT THE CONCRETE TO EXPOSE THE ENTIRE CIRCUMFERENCE OF THE REBAR. REMOVAL SHALL CONTINUE ALONG THE LENGTH OF THE REINFORCING STEEL UNTIL AT LEAST 6" OF UNCORRODED STEEL IS OBSERVED.
4. AT EDGE LOCATIONS, PROVIDE RIGHT ANGLE CUTS TO THE CONCRETE SURFACE WITH EITHER OF THE FOLLOWING METHODS:
  - 4.1. SAWCUT 1/2" (13 MM) OR LESS AS REQUIRED TO AVOID CUTTING REINFORCING STEEL.
  - 4.2. USE POWER EQUIPMENT SUCH AS HYDRODEMOLITION OR IMPACT BREAKERS. AVOID FEATHER EDGES.
  - 4.3. REPAIR CONFIGURATIONS SHOULD BE KEPT AS SIMPLE AS POSSIBLE, PREFERABLY WITH SQUARED CORNERS.
5. AFTER REMOVALS AND EDGE CONDITIONING ARE COMPLETE, REMOVE BOND INHIBITING MATERIALS (DIRT, CONCRETE SLURRY, LOOSELY BONDED AGGREGATES) BY ABRASIVE BLASTING OR HIGH PRESSURE WATERBLASTING WITH OR WITHOUT ABRASIVE.
6. CHECK THE CONCRETE SURFACES AFTER CLEANING TO INSURE THAT SURFACE IS FREE FROM ADDITIONAL LOOSE AGGREGATE, OR THAT ADDITIONAL DELAMINATIONS ARE NOT PRESENT.
7. IF HYDRODEMOLITION IS USED, CEMENT AND PARTICULATE SLURRY MUST BE REMOVED FROM PREPARED SURFACES BEFORE SLURRY HARDENS.

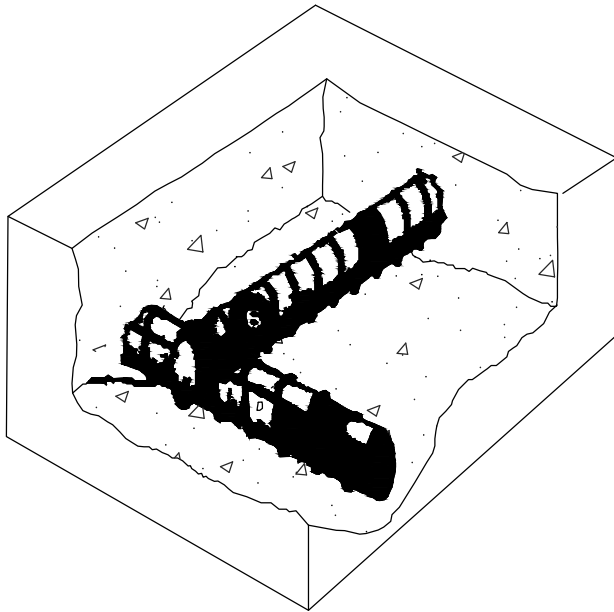

BOUNDARY OF LOOSE AND DELAMINATED CONCRETE

RECOMMENDED LAYOUT

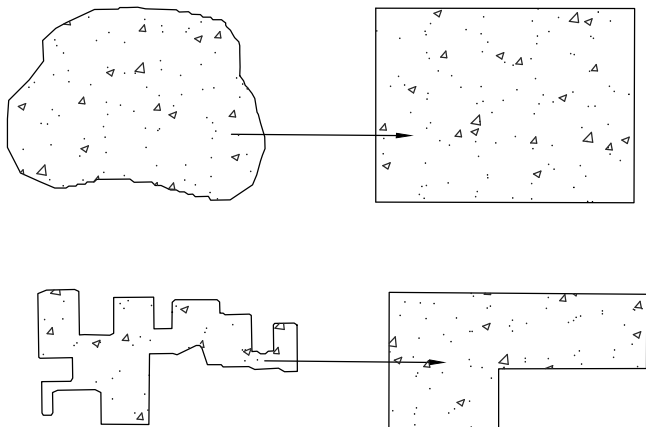

RODOLFO VILLAMIZAR  
FL. P.E.#61000

DATE:

LANTANA  
CONDOMINIUM  
BALCONY INSPECTION  
1811 A1A  
INDIAN HARBOUR BEACH, FL

DETAILS

**MBV**  
ENGINEERING INC.  
MOIA BOWLES VILLAMIZAR & ASSOCIATES  
CONSULTING ENGINEERING CA #3728

1835 - 20TH STREET  
VERO BEACH, FL 32960  
PH. (772) 569-0035  
FX. (772) 778-3617

MELBOURNE, FL - PH (321) 253-1510  
FT. PIERCE, FL - PH (772) 468-9055

JOB NO.	21-0530
DESIGNED	JT
DRAWN	AER
CHECKED	RV
DATE	DEC 2021
SHEET	15 OF XX

# SLAB WATER PROOFING

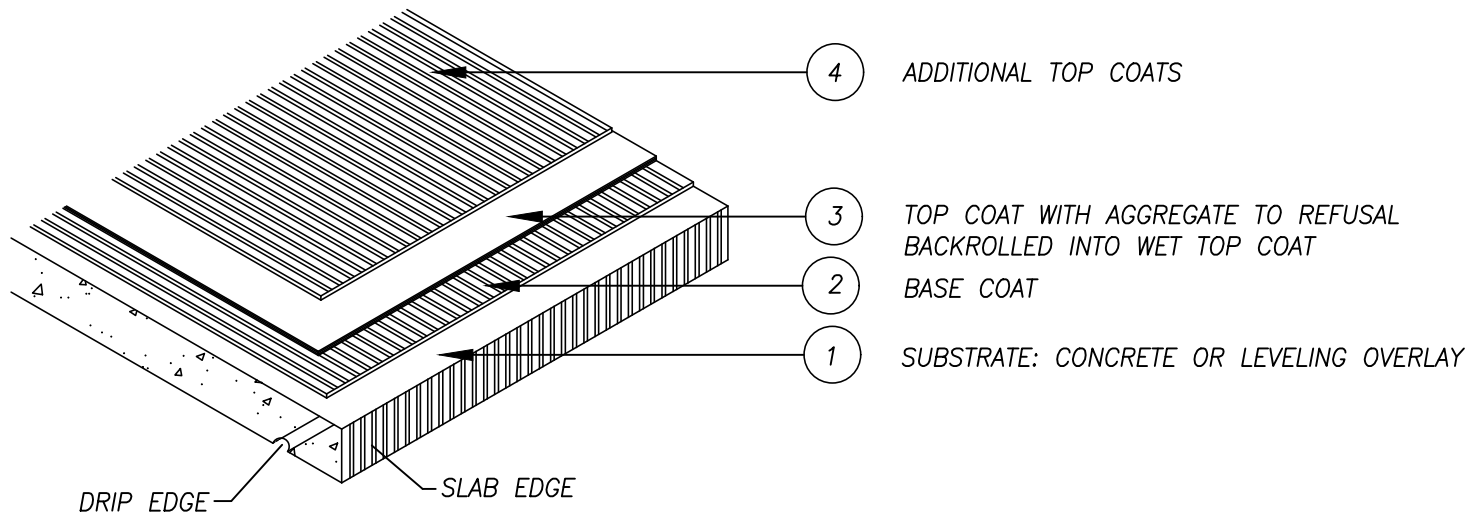

## REPAIR PROCEDURE:

1. ALLOW CONCRETE DECKS TO DRY FOR 48 HOURS MINIMUM WITHOUT RAINFALL. CONCRETE MUST BE VISIBLY DRY WITH MAXIMUM 4% MOISTURE CONTENT. IF REQUIRED BY THE ENGINEER, A MAT TEST SHALL BE PERFORMED ON ONE OR MORE DECKS PRIOR TO BASE COAT APPLICATION. TEST SHALL COVER AN AREA OF FOUR SQUARE FEET, MAT SHALL BE A 6 MIL CLEAR POLYURETHANE SHEET, SEALED ALL AROUND WITH ADHESIVE TAPE AND IT SHALL REMAIN IN PLACE FOR A MINIMUM OF 16 HOURS. CONCRETE DECKS SHALL BE DRY, CLEAN, SOUND AND FREE OF ALL CONTAMINANTS WHICH MAY INTERFERE WITH ADHESION OR PROPER CURING.
2. APPLY BASE COAT TO TOP OF SLAB AND VERTICAL EDGES PER MANUFACTURER'S SPECIFICATIONS AND ALLOW IT TO CURE BEFORE TOP COAT APPLICATION. EXTEND APPLICATION TO VERTICAL EDGE OF SLAB AND TO DRIP EDGE IF APPLICABLE.
3. AFTER SUFFICIENT CURE TIME, SURFACE DEFECTS SHALL BE REMEDIED, CONTRACTOR SHALL BE RESPONSIBLE FOR CORRECTING PONDING AREAS WITH COATINGS 3/16" OR LESS. ALLOW IT TO CURE FOR 72 HOURS MINIMUM BEFORE OPENING THE BALCONY TO TRAFFIC. TOP COAT APPLIED PER MANUFACTURER'S SPECIFICATIONS. BROADCAST SILICA SAND IMMEDIATELY INTO THE WET TOPCOAT AND BACK ROLL TO EVENLY DISTRIBUTE THE AGGREGATE. TOP COAT TO BE COMPATIBLE WITH BASE COAT.
4. APPLY FINAL TOP COATS PER MANUFACTURER'S INSTRUCTIONS.

TO THE BEST OF THE ARCHITECT'S OR ENGINEER'S KNOWLEDGE, THE PLANS AND SPECIFICATIONS COMPLY WITH THE APPLICABLE MINIMUM BUILDING CODES AND THE APPLICABLE FIRE SAFETY STANDARDS AS DETERMINED BY THE LOCAL AUTHORITY IN ACCORDANCE WITH FS553 AND FS633.

RODOLFO VILLAMIZAR  
FL. P.E.#61000

DATE:

LANTANA  
CONDOMINIUM  
BALCONY INSPECTION  
1811 A1A  
INDIAN HARBOUR BEACH, FL

DETAILS

**MBV**  
ENGINEERING, INC.  
MOJA BOWLES VILLAMIZAR & ASSOCIATES  
CONSULTING ENGINEERING CA #3728

1835 - 20TH STREET  
VERO BEACH, FL 32960  
PH. (772) 569-0035  
FX. (772) 778-3617

MELBOURNE, FL - PH (321) 253-1510  
FT. PIERCE, FL - PH (772) 468-9055

JOB NO.	21-0530
DESIGNED	JT
DRAWN	AER
CHECKED	RV
DATE	DEC 2021
SHEET	16 OF XX

# DECK OVERLAY SCALING / SLAB PITCH CORRECTION

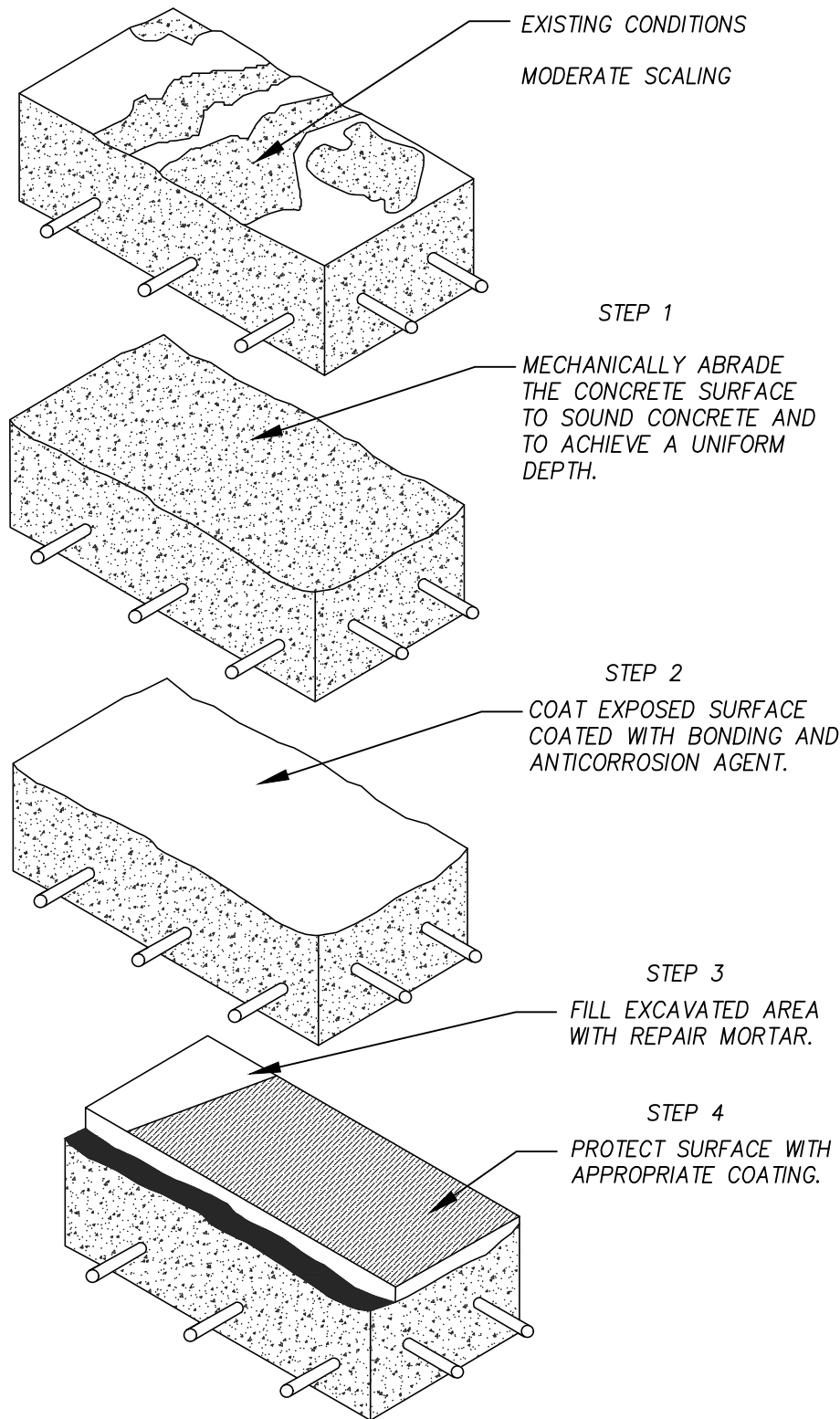

NOTES:

1. SPALL/SCALING UP TO 1/4" (7mm) IN DEPTH WITH MINOR AGGREGATE LOOSE, BUT NO EXPOSURE TO REBARS.
2. AN EXPOSED AGGREGATE PROFILE OF +/- 1/8" (3mm) IS REQUIRED IN ORDER TO OBTAIN A GOOD MECHANICAL BOND TO THE SUBSTRATE. PRESSURE WASH AFTER EXCAVATION TO REMOVE DUST, LAITANCE AND OTHER BOND INHIBITING MATERIALS, SSD SUBSTRATE.
3. APPLY A 20 MIL. COATING OF BONDING AND ANTI-CORROSION AGENT ONTO THE SSD SURFACE TO INSURE PROPER BOND OF REPAIR MATERIAL.
4. FILL AND SCREED EXCAVATED AREA WITH THE APPROPRIATE REPAIR MORTAR, CONSOLIDATE, FINISH AND CURE AS REQUIRED.

RODOLFO VILLAMIZAR  
FL. P.E.#61000

DATE:

# CONCRETE SPALLS: MODERATE

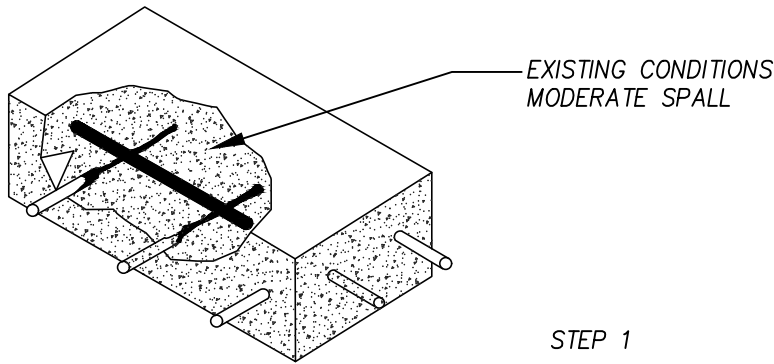

STEP 1

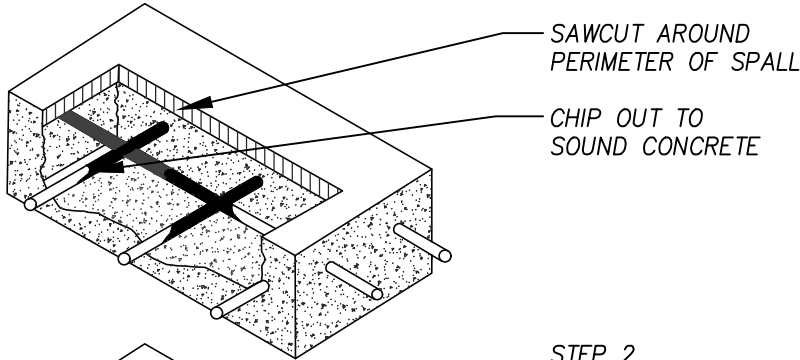

STEP 2

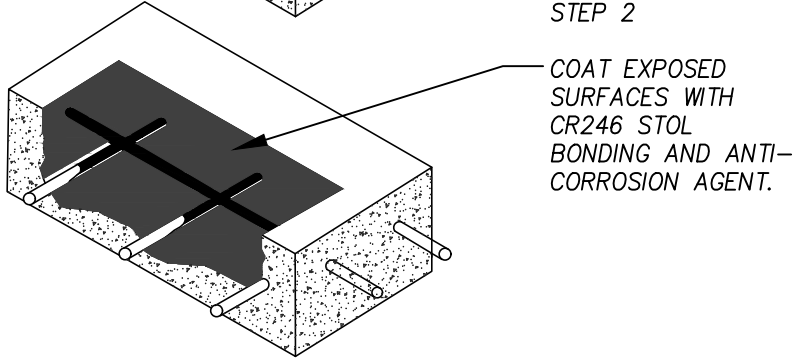

STEP 3

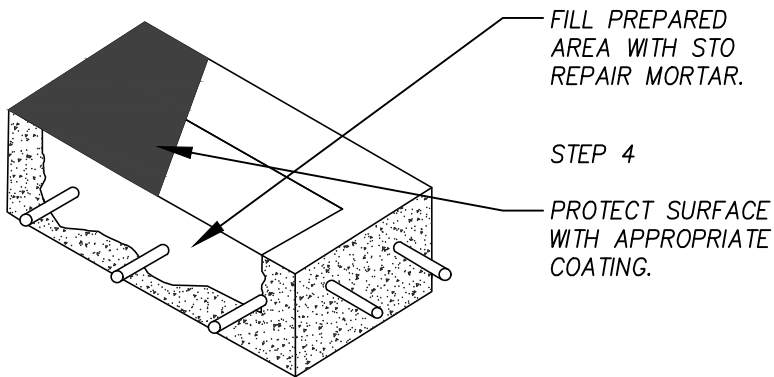

STEP 4

## NOTES:

1. MODERATE SPALLS ARE DEEPER THAN  $\frac{1}{4}$ " (7MM) WITH AGGREGATE LOSS, AND EXPOSED RE-BAR, BUT LESS THAN 30% OF SLAB THICKNESS.
2. REMOVE ALL DAMAGED OR UNSOUND CONCRETE FOLLOWING THE CONDITIONING OF CONCRETE GUIDELINES.
3. SAWCUT THE PERIMETER OF THE REPAIR AREA FORMING A SHOULDER PERPENDICULAR TO THE SUBSTRATE.
4. THE VERTICAL AND HORIZONTAL SURFACES SHALL BE ROUGHENED WITH  $\frac{1}{4}$ " AMPLITUDE.
5. SANDBLAST, HYDROBLAST, OR GRIND THE EXPOSED CONCRETE AND REBAR TO REMOVE DUST, LAITANCE AND OTHER BOND INHIBITING MATERIALS. AVOID DAMAGING OR CUTTING EXISTING REINFORCEMENT.
6. INSERT NEW BARS OF EQUAL DIAMETER NEXT TO THOSE THAT HAVE DETERIORATED BY MORE THAN 15%. ALL NEW STEEL SHALL BE ASTM A-615 GRADE 60. LAP SPLICES SHALL BE IN ACCORDANCE WITH ACI 318.
7. COAT ALL NEW AND EXISTING REBAR WITH TWO 10 MILS OF EPOXY, POLYMER CEMENT SLURRY OR A ZINC-RICH COATING FOR CORROSION PROTECTION. INSTALLATION SHALL BE DONE FOLLOWING THE MANUFACTURER SPECIFICATIONS.
8. THE BONDING AGENT SHALL BE INSTALLED AS DESCRIBED IN THE MANUFACTURER SPECIFICATIONS TO SSD (SATURATED-SURFACE- DRY) CONCRETE SURFACE.
9. FILL THE EXCAVATION WITH REPAIR MORTAR OR READY MIX CONCRETE PLACED AS DESCRIBED IN THE MANUFACTURER SPECIFICATIONS. REPAIR MIX SHALL HAVE A COMPRESSIVE RESISTANCE OF 5,000 PSI AT 28 DAYS AND A WATER CEMENT RATIO OF 0.45 OR LESS.
10. FINISH SURFACE TO TEXTURE AND SMOOTHNESS REQUIRED FOR THE SPECIFIC APPLICATION.
11. UPON COMPLETION OF FINISHING OPERATIONS, ALLOW MATERIAL TO CURE IN ACCORDANCE WITH MANUFACTURERS'S RECOMMENDATIONS.
14. APPLY PROTECTIVE WATERPROOF COATING TO PREPARED SUBSTRATE.
15. PROVIDE THE ARCHITECTURAL FINISH AS REQUIRED BY THE OWNER.
16. FOR MATERIAL SELECTION, PHYSICAL PROPERTIES, MIXING, APPLICATION AND CURING INFORMATION REFER TO APPROPRIATE TECHNICAL SPECIFICATIONS FROM MANUFACTURER.

RODOLFO VILLAMIZAR  
FL. P.E.#61000

DATE:

LANTANA  
CONDOMINIUM  
BALCONY INSPECTION  
1811 A1A  
INDIAN HARBOUR BEACH, FL

DETAILS

**MBV**  
ENGINEERING, INC.  
MOJA BOWLES VILLAMIZAR & ASSOCIATES  
CONSULTING ENGINEERING CA #3728

1835 - 20TH STREET  
VERO BEACH, FL 32960  
PH. (772) 569-0035  
FX. (772) 778-3617

MELBOURNE, FL - PH (321) 253-1510  
FT. PIERCE, FL - PH (772) 468-9055

JOB NO.	21-0530
DESIGNED	JT
DRAWN	AER
CHECKED	RV
DATE	DEC 2021
SHEET	18 OF XX

# FLASHING AT WALL

CEMENTITIOUS WATERPROOFING NOTES:

- SUBSTRATE SHALL BE PREPARED BY MECHANICAL MEANS TO REMOVE ALL BOND-INHIBITING MATERIALS TO SANDPAPER LIKE TEXTURE.
- FILL ALL VOIDS, REPAIR CONCRETE SPALLS, OR INSTALL REQUIRED SLOPING MATERIALS AS DIRECTED BY THE ENGINEER PRIOR TO INSTALLING THE WATERPROOFING SYSTEM.
- SUBSTRATE MUST BE THOROUGHLY SATURATED SURFACE DRY (SSD) PRIOR TO INSTALLING WATERPROOFING SYSTEM.

DECORATIVE COATING SYSTEM NOTES:

- ALLOW THE INSTALLED WATERPROOFING SYSTEM TO-CURE SO THAT THE SURFACE CAN TAKE FOOT TRAFFIC WITHOUT HARMING THE CEMENTITIOUS COATING.
- IF NECESSARY USE A RUBBING STONE TO SMOOTH OUT ANY TROWEL MARKS THAT APPEAR IN THE FINISH OF THE WATERPROOFING SYSTEM.
- RINSE OR BLOW OFF (WITH OIL-FREE COMPRESSED AIR) ENTIRE AREA TO REMOVE ALL DIRT, DUST, AND DEBRIS PRIOR TO INSTALLING COATING.

WATERPROOFING & ACRYLIC COATING SYSTEM (SIKAGARD-OPTION):

1. BASE COAT OF SIKAGARD FLEXCOAT AT 35-45 MILS THICK OVER ENTIRE SURFACE AREA.
2. TOP COAT OF SIKAGARD FLEXCOAT AT 35-45 MILS THICK OVER ENTIRE SURFACE AREA.
3. BASE COAT - SIKAGARD FLEXCOAT ATC, APPLY WITH ROLLER, BRUSH OR SPRAY EQUIPMENT AT A UNIFORM THICKNESS OF APPROXIMATELY 5-6 WET MILS.
  - ALLOW TO COMPLETELY DRY.
4. TOP COAT - SIKAGARD FLEXCOAT ATC, APPLY WITH ROLLER, BRUSH OR SPRAY EQUIPMENT AT A UNIFORM THICKNESS OF APPROXIMATELY 5-6 WET MILS.
  - **ALLOW TO COMPLETELY DRY PRIOR TO ALLOWING FOOT TRAFFIC.**
5. CONTINUOUS CANT BEAD - SIKAFLEX 2C NS OR SIKAFLEX 1A AND APPROPRIATE SIKAFLEX PRIMER (PRIME AS REQUIRED) ALONG ENTIRE PERIMETER OF SLAB TO WALL TRANSITION AND ALL DOOR THRESHOLDS.
  - REFER TO SEALANT AND PRIMER TECHNICAL DATA SHEETS FOR INSTALLATION REQUIREMENTS.

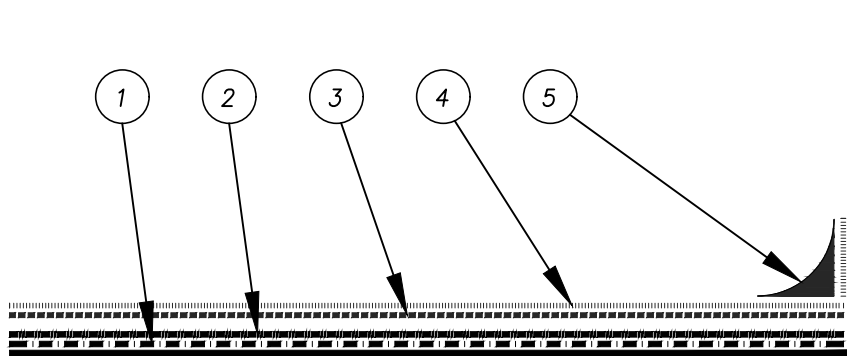

RODOLFO VILLAMIZAR  
FL. P.E.#61000

DATE:

LANTANA  
CONDOMINIUM  
BALCONY INSPECTION  
1811 A1A  
INDIAN HARBOUR BEACH, FL

DETAILS

**MBV**  
ENGINEERING, INC.  
MOIA BOWLES VILLAMIZAR & ASSOCIATES  
CONSULTING ENGINEERING CA #3728

1835 - 20TH STREET  
VERO BEACH, FL 32960  
PH. (772) 569-0035  
FX. (772) 778-3617  
  
MELBOURNE, FL - PH (321) 253-1510  
FT. PIERCE, FL - PH (772) 468-9055

JOB NO.	21-0530
DESIGNED	JT
DRAWN	AER
CHECKED	RV
DATE	DEC 2021
SHEET	19 OF XX

# WALL REPAIR

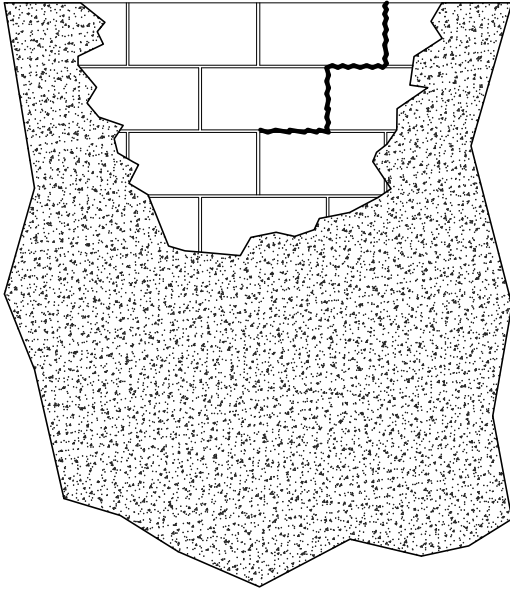

## NOTES FOR GENERAL REPAIR:

1. CHIP AND REMOVE CRACKED MORTAR OR LOOSE WALL CONCRETE.
2. THOROUGHLY CLEAN MASONRY SUBSTRATE AND REMAINING STUCCO SURFACES (EXPOSED EDGES INCLUDED) WITH CONCRETE/MASONRY CLEANER OR TRISODIUM PHOSPHATE/WATER SOLUTION.
3. REPAIR CRACKED AND/OR SPALLED MASONRY SUBSTRATE INCLUDING CONCRETE BLOCK UNITS, MORTAR JOINTS, AND GROUT FILLED CELLS IN ACCORDANCE WITH REPAIR DETAILS AND SPECIFICATIONS PROVIDED HEREIN.
4. REPAIR CRACKS WITH "UGL DRYLOK MASONRY CRACK FILLER", "ELASTIPOXY" OR SIMILAR EPOXY JOINT & CRACK FILLER MATERIAL; FOLLOWING THE MANUFACTURER'S RECOMMENDATIONS. FOR LARGER CRACKS TO PREVENT THE EPOXY FROM RUNNING OUT OF THE CRACK, INSERT FOAM BACKER ROD OF SUITABLE DIAMETER OR FILL IN WITH CAULK.
5. FILL HOLLOW CORE HOLES WITH EXPANDABLE FOAM FILLER MATERIAL TO PROVIDE A BACKING SUBSTRATE.
6. COAT ALL SIDES OF GAP/HOLE WITH BONDING AGENT.
7. PATCH REPAIR AREAS WITH NEW REPAIR MORTAR SYSTEM OR EXTERIOR STUCCO SYSTEM IN ACCORDANCE WITH THE MANUFACTURER'S SPECIFICATIONS.
8. MATCH EXISTING FINISH TEXTURE AND COLOR AS CLOSE AS POSSIBLE.
9. FINISH/PAINT/COAT REPAIRED AREA IN ACCORDANCE WITH THE GENERAL NOTES.

RODOLFO VILLAMIZAR  
FL. P.E.#61000

DATE:

LANTANA  
CONDOMINIUM  
BALCONY INSPECTION  
1811 A1A  
INDIAN HARBOUR BEACH, FL

DETAILS

**MBV**  
**ENGINEERING, INC.**  
MOIA BOWLES VILLAMIZAR & ASSOCIATES  
CONSULTING ENGINEERING CA #3728

1835 - 20TH STREET  
VERO BEACH, FL 32960  
PH. (772) 569-0035  
FX. (772) 778-3617

MELBOURNE, FL - PH (321) 253-1510  
FT. PIERCE, FL - PH (772) 468-9055

JOB NO.	21-0530
DESIGNED	JT
DRAWN	AER
CHECKED	RV
DATE	DEC 2021
SHEET	20 OF XX